

Downlight fitting

IP
44/20

EA
SY
Installation



Kanlux ROUNDA V2LED is a new version of popular round downlight luminaires for indoor use. The downlights combine aesthetic design with light obtained thanks to LED technology. No water or dust can get to the inside owing to the high class of tightness (IP44).

GENERAL DATA:

Colour: white

Place of assembly: Recessed mount in the ceiling

Place of application: Indoors

Minimum distance from the illuminated object: 0,5m

Compatible with a dimmer: no

The product is not suitable to be covered with a heat-insulating material: yes

Height [mm]: 20

Diameter [mm]: 220

Assembly hole [mm]: Ø208

Integrated LED light source: yes

TECHNICAL DATA:

Rated voltage [V]: 220-240 AC

Rated frequency [Hz]: 50

Maximum power [W]: 18

Class of protection against electric shock: II

Lampshade material: plastic

Diode type: LED SMD

Luminous flux [lm]: 1200

Useful luminous flux of the light source Φ_{use} [lm]: 2000

Useful luminous flux of the light source Φ_{use} [lm]: in sphere (360°)

Colour temperature: Warm white

Correlated colour temperature [K]: 3000

Colour consistency in McAdam ellipses: 6

Colour rendering index: 80

Cap (Light source): wires

Service life [h]: 15000

Number of on/off cycles: ≥ 20000

Lighting angle [°]: 110

Luminous efficiency of the lamp [lm/W]: 67

Ambient temperature range to which the product can be exposed: 5÷25

Enclosure material: aluminum alloy

Connection type: Free cable ends



28935 ROUNDA V2LED18W-WW-W

Downlight fitting

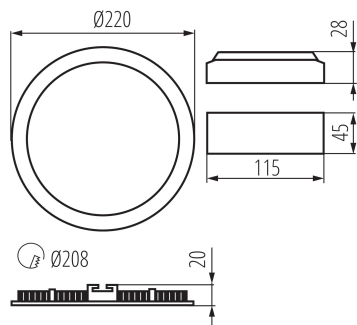

Wire length [m]: 0.05

Wire diameter [mm²]: 0.75

Lamp-heating time [s]: ≤ 1

Lamp-ignition time [s]: $\leq 0,5$

IP class: 44/20

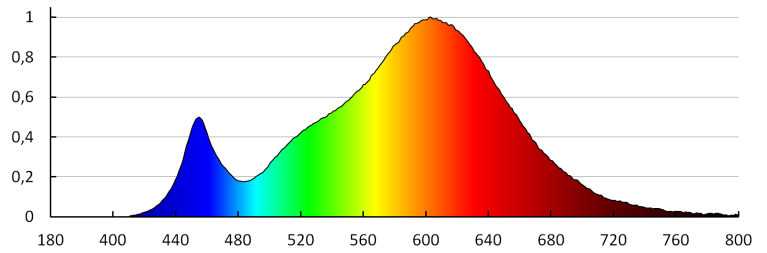

KANLUX S.A. (kat 28935) ROUNDA V2LED18W-WW-W / LDC (Polar)

Luminaire: KANLUX S.A. (kat 28935) ROUNDA V2LED18W-WW-W
Lamps: 1 x ROUNDA V2LED18W-WW-W

