

STRETON LED

Pouliční LED svítidlo



[V] 220-240 AC	[Hz] 50	360° Φ _{use}	≥20000	50000 ^[h]	ellipse ≤ 6x MacAdam	Ra 70
SMD			IP 65		[-20÷45] °C	
IK 08		[m] 0,4	[mm²] 1	1m	Hg	CE
EAC	UK CA					



STRETON LED 20W NW



Model	Power [W]	Beam angle [lm] Φ _{use}	Temperature Tc [K]	Beam angle [°]	Efficacy [lm/W]	Color	Grade
STRETON LED 20W NW	36228	20	2800	4000	X140/Y90	šedá	D
STRETON LED 40W NW	36229	40	5600	4000	X140/Y90	šedá	D
STRETON LED 60W NW	36230	60	8400	4000	X140/Y90	šedá	D
STRETON LED 100W NW	36231	100	14000	4000	X140/Y90	šedá	D
STRETON LED 150W NW	36232	150	19500	4000	X140/Y90	šedá	E
STRETON LED 200W NW	36233	200	26000	4000	X140/Y90	šedá	E

5 let záruky shodně s podmínkami záručního prohlášení dostupného na [internetové stránce](#)

Kanlux STRETON LED jsou venkovní svítidla určená k osvětlení parkovišť nebo větších ploch, které musí být dobře osvětleny i po setmění. Jejich životnost (50 000 hodin), odolnost (IP65) a vysoký výkon (až 200 W) dělají z Kanlux STRETON LED perfektní doplněk k investici do městského prostoru, na parkoviště, do sportovních zařízení nebo náměstí.

- Materiál korpusu: hliníková slitina
- Materiál ochranného skla: PC

STRETON LED

Pouliční LED svítidlo



STRETON LED 20W NW



STRETON LED 40W NW

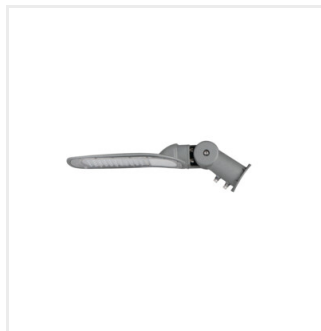

STRETON LED 60W NW



STRETON LED 100W NW



STRETON LED 150W NW



STRETON LED 200W NW

STRETON LED

Pouliční LED svítidlo

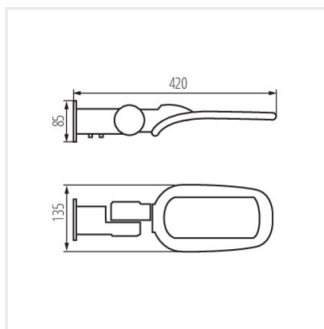

STRETON LED 20W NW

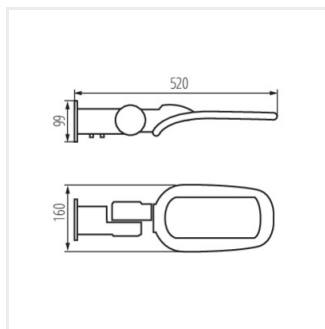

STRETON LED 40W NW

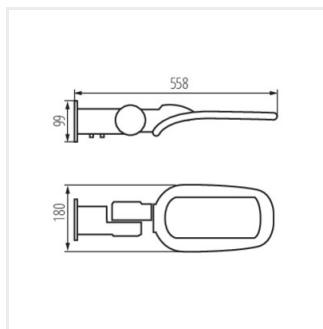

STRETON LED 60W NW

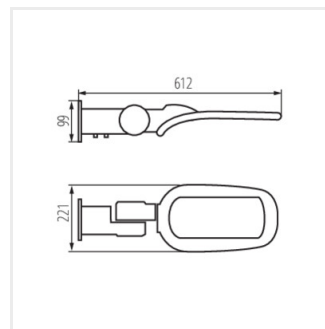

STRETON LED 100W NW

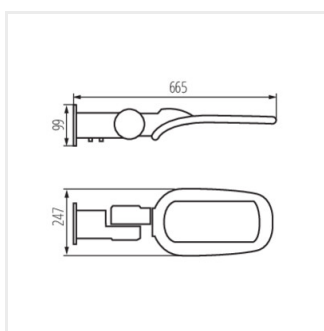

STRETON LED 150W NW

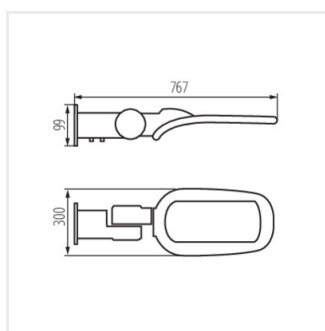

STRETON LED 200W NW

OPTION 1

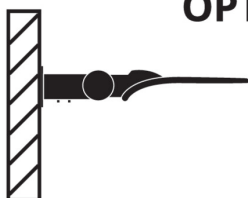

OPTION 2

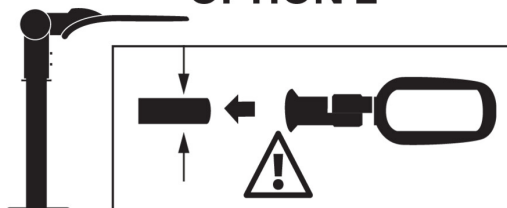

STRETON 20W: Ø42-48

STRETON 40W/60W/100W/150W/200W: Ø50-62