

23861 DRIVE LED N 15W 12V

Elektronischer Transformator



[Hz] 50	CV 	PRI [V] 220 - 240	SEC [V] 12 DC	SEC [mA] max 1250		IP 20
			 [mm ²] 0,5÷1,5		CE	EAC
UK CA						



DRIVE LED N 15W 12V **23861** 220-240 AC max 15

- Das Netzgerät ist nicht für den Leerlaufbetrieb geeignet.
- Material: Kunststoff

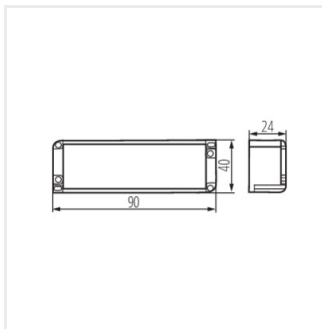

DRIVE LED N 15W 12V