

## ESG LED

### LED light source



### ESG LED 9W GX53



ESG LED 9W GX53-WW	<b>22422</b>	9	720	595	3000	110	GX53	G
ESG LED 9W GX53-NW	<b>22423</b>	9	750	600	4000	110	GX53	G
ESG LED 9W GX53-CW	<b>22424</b>	9	750	600	6000	110	GX53	G

Kanlux ESG LED is characterised by aesthetic design and durable construction. The matte shade guarantees an even and wide light distribution. White housing made of aluminium ensures proper heat dissipation and high performance SMD LEDs ensure durability for 20.000 h.

- Material: aluminum alloy, plastic

## ESG LED

LED light source



ESG LED 9W GX53

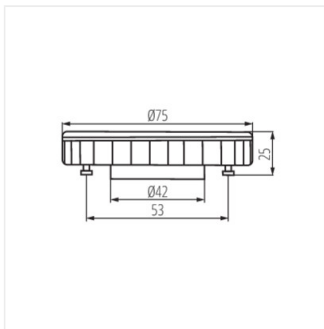

ESG LED 9W GX53