

HIBO LED N

Luminaire LED high bay



[V] 220-240 AC	[Hz] 50	[°] 120	≥20000	[h] 25000	ellipse ≤ 6x MacAdam Ra 80
SMD	IP 65		IP 65	[°C] -20÷40	
	[m] 0,45	[mm²] 1		1m	120° Φ _{use}

HIBO LED N 50W-NW



	P _{ON} [W]	[lm]	[lm] Φ _{use}	T _c [K]		
HIBO LED N 50W-NW	31111	50	4750	4000	4000	noir F
HIBO LED N 100W-NW	31112	100	10000	8200	4000	noir F
HIBO LED N 150W-NW	31113	150	15000	12300	4000	noir F
HIBO LED N 200W-NW	31114	200	20000	16450	4000	noir F

HIBO LED est un luminaire de type « High Bay » utilisant un module à LED à diodes SMD. Le luminaire a un degré d'étanchéité élevé IP65 et peut donc être monté dans des endroits très poussiéreux et exposés à l'eau. C'est un luminaire industriel, idéal pour l'éclairage des entrepôts, des halls de production et des grands espaces commerciaux.

- Matériau du boîtier: alliage en aluminium
- Matériau vitre de protection: verre

HIBO LED N

Luminaire LED high bay



HIBO LED N 50W-NW



HIBO LED N 100W-NW



HIBO LED N 150W-NW



HIBO LED N 200W-NW

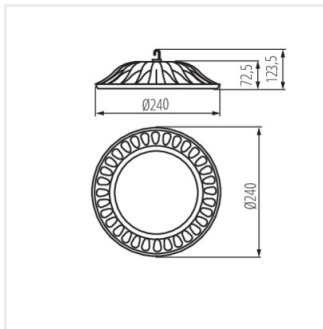

HIBO LED N 50W

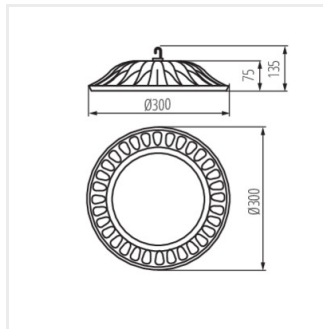

HIBO LED N 100W

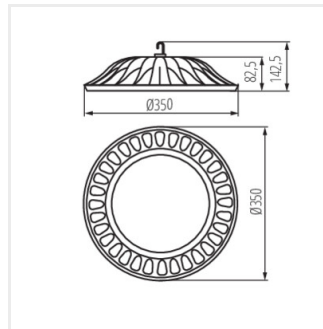

HIBO LED N 150W

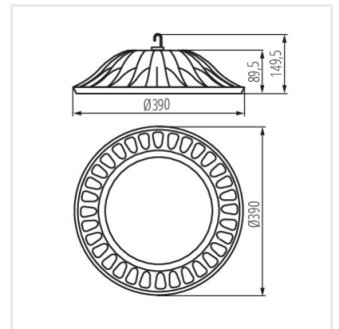

HIBO LED N 200W