

37347 XLED HP D46E40 38W-NW

Source lumineuse LED



[V] 220-240 AC	[Hz] 50	FILAMENT	360° Φ _{use}	ellipse ≤ 6x Nachdam	Ra 70	≥7500
25000 [h]	Hg		[-20÷45] [°C]	IP 65	CE	
EAC	UK CA					



XLED HP D46E40 38W-NW **37347** 38 402 7500 4000 320 E40 B

- Pour les utilisations industrielles (par exemple dans les usines, les entrepôts, etc.)
- Une garantie de 3 ans accordée conformément aux termes de la déclaration de garantie disponible sur le site d'Internet
- Matériau du diffuseur: verre

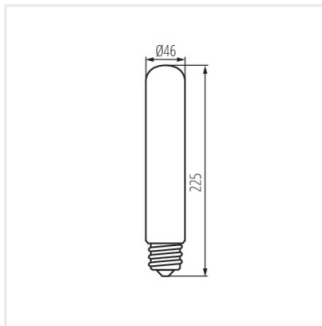

XLED HP D46E40 38W-NW