

RANGO LED

Lampadina led

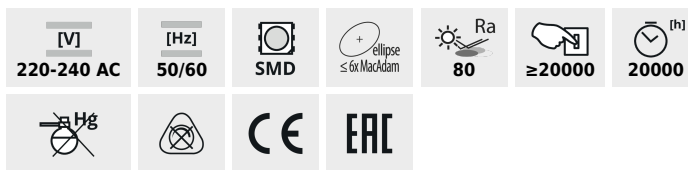

RANGO R7S SMD



RANGO R7S SMD-WW	15098	6	550	3000	120	R7s	F	
RANGO MINI R7S SMD-WW	15099	6	510	3000	120	R7s	F	

La sorgente luminosa a LED Kanlux RANGO è una soluzione perfetta a basso consumo energetico per tutti i tipi di lampade e proiettori con l'attacco R7s.

- Materiale: materiale plastico
- Materiale del diffusore: vetro



RANGO LED

Lampadina led



RANGO R7S SMD



RANGO MINI R7S SMD-WW

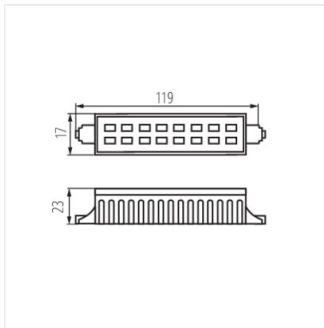

RANGO R7S SMD

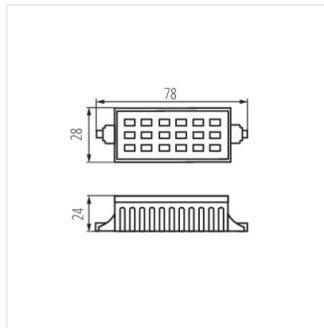

RANGO MINI R7S SMD