

## 37347 XLED HP D46E40 38W-NW

Lampadina led



[V] 220-240 AC	[Hz] 50	FILAMENT	360° Φ <sub>use</sub>	ellipse ≤ 6x Nachdam	Ra 70	≥7500
[h] 25000	Hg		[°C] -20÷45		IP 65	CE
EAC	UK CA					



XLED HP D46E40 38W-NW **37347** 38 402 7500 4000 320 E40 B

- Per applicazioni industriali (ad esempio in capannoni, magazzini, ecc.)
- Tre anni di garanzia secondo i termini e le condizioni presenti nel sito [www.kanlux.com](http://www.kanlux.com)
- Diffusore: vetro

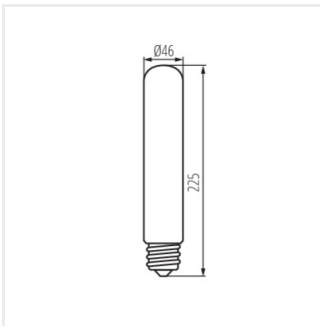

XLED HP D46E40 38W-NW