

## 37390 CALIZA LED CCT W

Lampada da parete LED

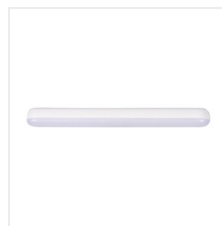

3,7 DC ACCU	max 160	≥15000	25000	3000/4000/6500	≤6x Macchdam	80
SMD			IP 20		5÷25	
180	0,1m		max 80			



CALIZA LED CCT W **37390** max 2 bianco

Kanlux CALIZIA LED è una lampada da parete moderna con un flusso luminoso di 160 lm, Viene caricata tramite USB C (il set include un cavo da 220 mm). Il supporto magnetico può essere ancorato alle pareti o negli armadi tramite due 2 viti (incluso nel set), la lampada si sgancia per una facile ricarica. Kanlux CALIZIA LED permette di cambiare il colore della luce da calda a neutra o fredda. Il tempo di funzionamento della lampada è di 5 ore consecutivamente accesa.

- Materiale del corpo: plastica
- Diffusore: plastica

## 37390 CALIZA LED CCT W

Lampada da parete LED

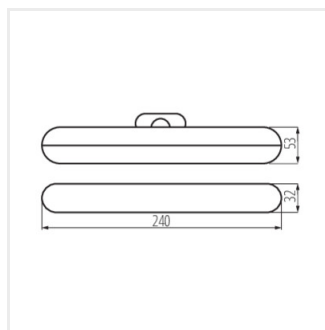

CALIZA LED CCT W