

23800 APUS LED AC-WW

Staircase LED light fitting

5905339238009



APUS LED AC

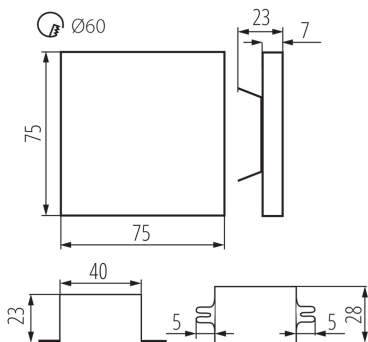
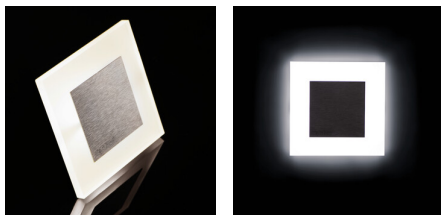

Kanlux APUS means modern design combined with an attractive effect of lighting. It is a perfect idea to highlight stairs and corridors or to emphasize decor of rooms. The unique structure of the holders ensures even emission of light. The AC version is equipped with 230V power supply unit which fits into a box and the PIR version is equipped with a motion sensor. The sensor detects movement / turns lights on regardless of the ambient light intensity.

GENERAL DATA:

To be built into the wall: yes

Colour: stainless steel

Place of assembly: Recessed mount in the wall

Place of application: Indoors

Minimum distance from the illuminated object: 0,1m

Compatible with a dimmer: no

Feeder included: yes

Length [mm]: 75

Width [mm]: 23

Height [mm]: 75

Required diameter of the assembly box [Ømm]: 60

Assembly-hole dimensions [mm]: 60

Integrated LED light source: yes

TECHNICAL DATA:

Rated voltage [V]: 220-240 AC

Rated frequency [Hz]: 50

Maximum power [W]: 1.3

Class of protection against electric shock: II

Diode type: LED SMD

Luminous flux [lm]: 13

Colour temperature: Warm white

Correlated colour temperature [K]: 3000

Colour consistency in McAdam ellipses: ≤6

Colour rendering index: 80

Service life [h]: 50000

Number of on/off cycles: ≥20000

Luminous efficiency of the lamp [lm/W]: 10

Ambient temperature range to which the product can be exposed: 5÷25

Enclosure material: polished stainless steel, plastic

Connection type: Free cable ends

Wire length [m]: 0.18

Lamp-heating time [s]: ≤1

Staircase LED light fitting



Lamp-ignition time [s]: ≤0,5

IP class: 20

LOGISTIC DATA:

Unit of measurement: unit

Packaging method: 100

Number of units in the secondary packaging : 1

Number of units in the packaging: 100

Net unit weight [g]: 120

Grammage [g]: 124.9

Length of a unit pack [cm]: 11

Width of a unit pack [cm]: 2.5

Height of a unit pack [cm]: 16.5

Weight of a cardboard box [kg]: 12.49

Width of a cardboard box [cm]: 34.5

Height of a cardboard box [cm]: 34.5

Length of a cardboard box [cm]: 63

Volume of a cardboard box [m³]: 0.074986

ADDITIONAL INFORMATION:

- the fitting is suitable for mounting in Ø 60 junction boxes.
- fitting delivered with a power supply unit fit for Ø 60 junction box, enabling powering from grids with voltage of 220-240 V

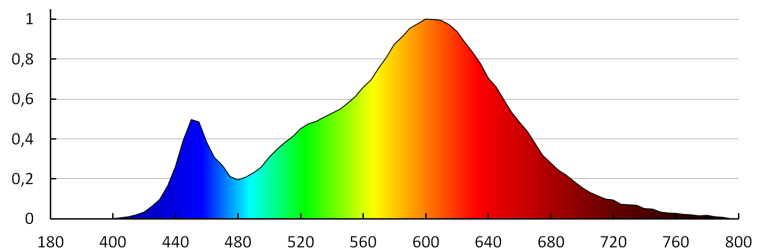

23800 APUS LED AC-WW

Staircase LED light fitting

KANLUX S.A. (kat 23800) APUS LED AC-WW / LDC (Polar)

Luminaire: KANLUX S.A. (kat 23800) APUS LED AC-WW
Lamps: 1 x APUS LED WW

