

## 24906 DOMO 01-1190-141 gr

Energy Saving Switch - Delayed Power Off

5905339249067

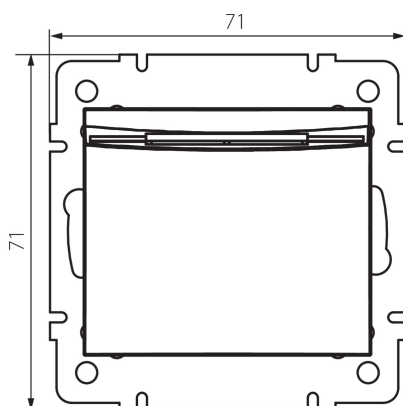

### GENERAL DATA:

**Colour:** graphite  
**Place of assembly:** Recessed mount in the wall  
**Highlighting:** Not applicable  
**Width [mm]:** 71  
**Height [mm]:** 71  
**Diameter of an installation box:** 60  
**Installation depth:** 25

### TECHNICAL DATA:

**Rated voltage [V]:** 250 AC  
**Class of protection against electric shock:** II  
**Material:** PC  
**Material of contacts:** CuSn94  
**Terminal type:** Screw terminal  
**Plastic:** PC  
**Rated current [AX]:** 10  
**IP class:** 20

### LOGISTIC DATA:

**Packaging method:** 10  
**Number of units in the secondary packaging:** 10  
**Number of units in the packaging:** 120  
**Net unit weight [g]:** 64  
**Grammage [g]:** 82.83  
**Length of a unit pack [cm]:** 9  
**Width of a unit pack [cm]:** 5  
**Height of a unit pack [cm]:** 14  
**Weight of a cardboard box [kg]:** 9.9396  
**Width of a cardboard box [cm]:** 26.5  
**Height of a cardboard box [cm]:** 32  
**Length of a cardboard box [cm]:** 44  
**Volume of a cardboard box [m<sup>3</sup>]:** 0.037312

**24906** DOMO 01-1190-141 gr

---

Energy Saving Switch - Delayed Power Off