

25076 LOGI 02-1090-102 bi

Triple switch

5905339250766

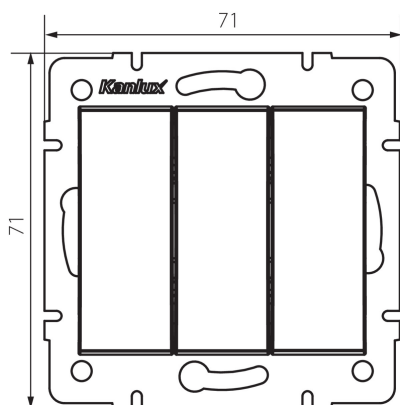

A three-gang light switch is used to control the circuit of three lamps or three groups of lamps from one place.

GENERAL DATA:

Colour: white

Place of assembly: Recessed mount in the wall

Highlighting: no

Width [mm]: 71

Height [mm]: 71

Diameter of an installation box: 60

Installation depth: 25

TECHNICAL DATA:

Rated voltage [V]: 250 AC

Material of contacts: CuZn70

Terminal type: Screw terminal

Plastic: ABS

Number of levers: 3

Rated current [AX]: 10

IP class: 20

LOGISTIC DATA:

Packaging method: 10

Number of units in the secondary packaging: 10

Number of units in the packaging: 120

Net unit weight [g]: 74

Grammage [g]: 86.25

Length of a unit pack [cm]: 10

Width of a unit pack [cm]: 4.5

Height of a unit pack [cm]: 14

Weight of a cardboard box [kg]: 10.35

Width of a cardboard box [cm]: 25.5

Height of a cardboard box [cm]: 32

Length of a cardboard box [cm]: 44

Volume of a cardboard box [m³]: 0.035904

25076 LOGI 02-1090-102 bi

Triple switch