

Downlight fitting

5905339289438

IP
44/20

EA
SY
Installation

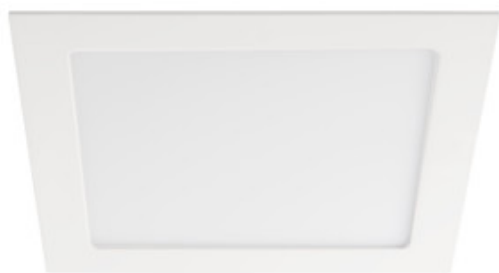

Kanlux KATRO V2LED is a new version of KATRO N LED luminaires, popular square downlights for indoor use. They combine aesthetic design with light obtained owing to LED technology. No water or dust can get to the inside owing to the high class of tightness (IP44).

GENERAL DATA:

Colour: white

Place of assembly: Recessed mount in the ceiling

Place of application: Indoors

Minimum distance from the illuminated object: 0,5m

Compatible with a dimmer: no

The product is not suitable to be covered with a heat-insulating material: yes

Length [mm]: 225

Width [mm]: 225

Height [mm]: 20

Assembly hole [mm]: 208x208

Integrated LED light source: yes

TECHNICAL DATA:

Rated voltage [V]: 220-240 AC

Rated frequency [Hz]: 50

Maximum power [W]: 18

Class of protection against electric shock: II

Lampshade material: plastic

Diode type: LED SMD

Luminous flux [lm]: 1260

Useful luminous flux of the light source Φ_{use} [lm]: in sphere (360°)

Colour temperature: white

Correlated colour temperature [K]: 4000

Colour consistency in McAdam ellipses: ≤ 6

Colour rendering index: 80

Service life [h]: 15000

Number of on/off cycles: ≥ 20000

Lighting angle [°]: 110

Luminous efficiency of the lamp [lm/W]: 70

Ambient temperature range to which the product can be exposed: 5÷25

Enclosure material: aluminum alloy

Reflector material: 0.75

Connection type: Free cable ends

Wire length [m]: 0.05

Wire diameter [mm²]: 0.75

28943 KATRO V2LED 18W-NW-W

Downlight fitting

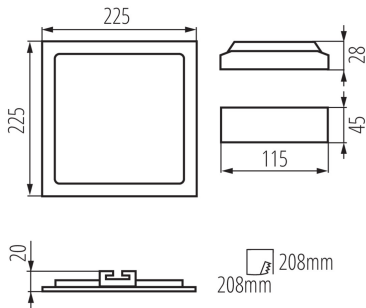

Lamp-heating time [s]: ≤ 1
Lamp-ignition time [s]: $\leq 0,5$
IP class: 44/20

LOGISTIC DATA:

Packaging method: 20
Number of units in the secondary packaging: 1
Number of units in the packaging: 20
Net unit weight [g]: 470
Grammage [g]: 600
Length of a unit pack [cm]: 23
Width of a unit pack [cm]: 3
Height of a unit pack [cm]: 29
Weight of a cardboard box [kg]: 12
Width of a cardboard box [cm]: 34
Height of a cardboard box [cm]: 31
Length of a cardboard box [cm]: 48
Volume of a cardboard box [m³]: 0.050592

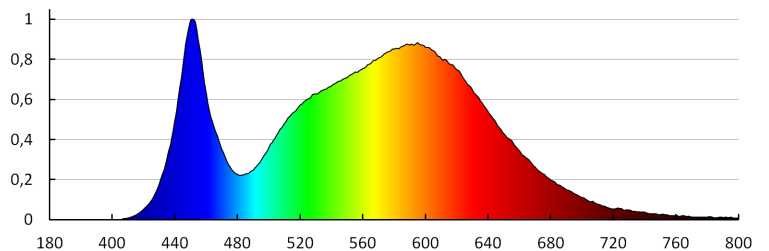

KANLUX S.A. (kat 28943) KATRO V2LED18W-NW-W / LDC (Polar)

Luminaire: KANLUX S.A. (kat 28943) KATRO V2LED18W-NW-W
Lamps: 1 x KATRO V2LED18W-NW-W

