

## 33617 LOGI 02-1010-142 cm

Double One Way Switch

5905339336170

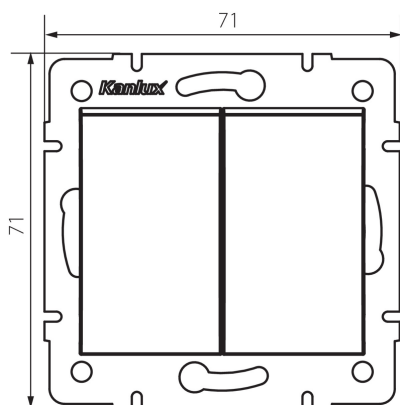

A two-gang light switch is used to control circuits of two lamps or two groups of lamps from one place.

### GENERAL DATA:

**Colour:** black matt  
**Place of assembly:** Recessed mount in the wall  
**Width [mm]:** 71  
**Height [mm]:** 71  
**Diameter of an installation box:** 60  
**Installation depth:** 25

### TECHNICAL DATA:

**Rated voltage [V]:** 250 AC  
**Material of contacts:** CuZn70  
**Terminal type:** Screw terminal  
**Plastic:** ABS  
**Number of levers:** 2  
**Rated current [AX]:** 10  
**IP class:** 20

### LOGISTIC DATA:

**Packaging method:** 10  
**Number of units in the secondary packaging:** 10  
**Number of units in the packaging:** 120  
**Net unit weight [g]:** 74  
**Grammage [g]:** 86.5  
**Length of a unit pack [cm]:** 10  
**Width of a unit pack [cm]:** 4  
**Height of a unit pack [cm]:** 14  
**Weight of a cardboard box [kg]:** 10.38  
**Width of a cardboard box [cm]:** 25.5  
**Height of a cardboard box [cm]:** 32  
**Length of a cardboard box [cm]:** 44  
**Volume of a cardboard box [m<sup>3</sup>]:** 0.035904

## **33617** LOGI 02-1010-142 cm

---

Double One Way Switch